

# HI-G<sup>®</sup> DEWATERING MACHINE

# HI-G<sup>®</sup> DEWATERING MACHINE

---

## Serving the Mining & Industrial Markets

The Derrick HI-G<sup>®</sup> Dewatering machine provides the most cost-effective solution to handling fine solids separation. Derrick HI-G Dewatering machines utilize a combination of small diameter hydrocyclones mounted over a Linear Motion machine to recover and dewater solids as fine as 325 mesh (45 microns). Numerous HI-G Dewatering machines can be found operating in sand, aggregate, coal, concrete, graphite, and other mining dewatering applications worldwide.

## FEATURES & BENEFITS

---

### Hydrocyclones

- Up to two clusters of twenty 4" hydrocyclones
- Designed to remove silt-sized solids (20-74 microns)
- Optional individual shutoff valve for each 4" hydrocyclone

### Super G Integrated Vibratory Motors

- Zero maintenance
- Powerful, quiet, dual vibratory motors apply high G performance
- Standard Super G has greased-for-life bearings

### Polyweb Urethane Screens Panels

- High open area for maximum flow capacity
- Unique non-blinding design for optimum efficiency and performance
- Long lasting – average panel life is 6 to 18 months (10 to 20 times longer than woven wire panels)

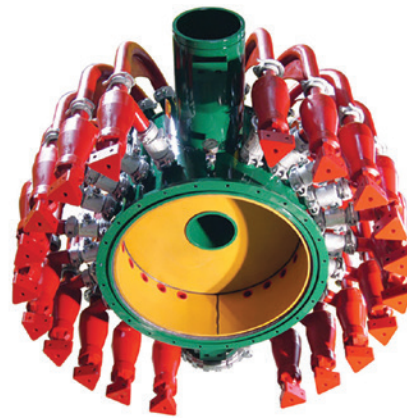

Rubber Lined Manifold



HI-G Dewatering Machine

# HI-G FINES RECOVERY SYSTEM

### System Operation

Wash plant discharge is directed to the custom-designed two-chambered sump. A heavy duty sand slurry pump feeds the Derrick 4" hydrocyclones that are mounted on a radial-designed manifold. The centrifugal separation extracts the ultra fine sands and silts, discharging them out the underflow. The fines leave the hydrocyclone and are fed to the high G performance dewatering screen.

The Derrick HI-G Dewatering Machine is outfitted with two 2.5 HP electromechanical vibratory motors that operate at 1,750 RPM. The combination of stroke length and rotation speed create high G performance on the screen surface, resulting in efficient separation of water from the fine solids. The dewatered fine solids are then discharged from the screening machine.

The Derrick HI-G Fines Recovery System provides the Mining & Industrial markets with unparalleled performance and unmatched cost-effectiveness in handling by-product fines.

- Recover up to 80% of the silts and ultra fine sands reporting to your settling pond
- Reduce pond cleaning maintenance costs and extend the life of your settling pond
- Turn a once wasted material into a marketable product
- Requires no expensive polymers or chemicals



HI-G Fines Recovery System

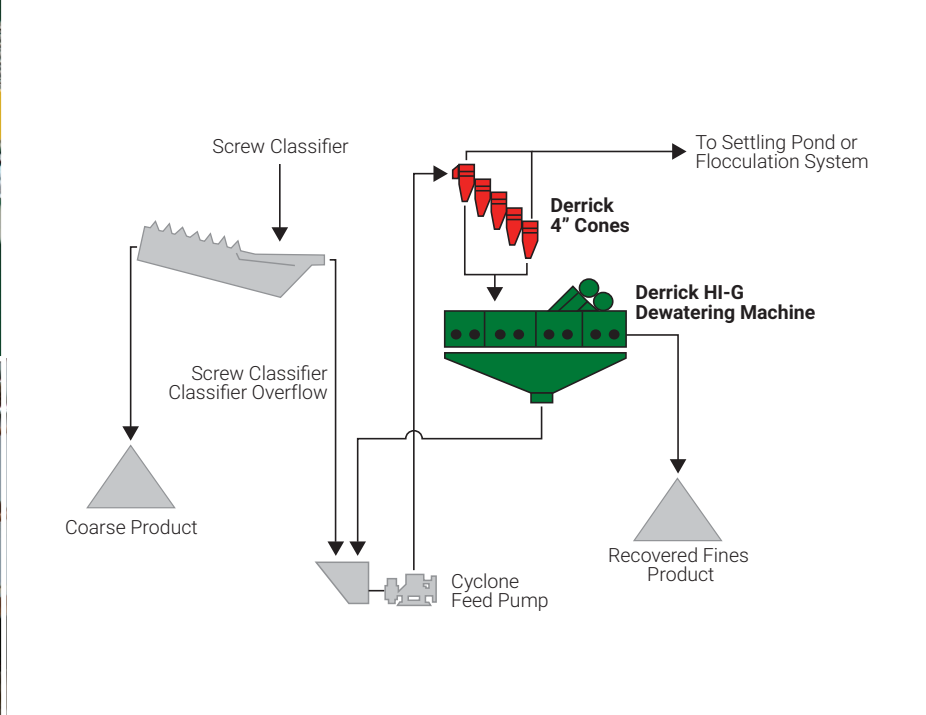



Since 1951, Derrick has manufactured premium fine-separation technology. From ruggedly dependable dewatering equipment to long-lasting urethane screen panels, Derrick's innovative technologies are applicable to a global customer base and many worldwide markets.

Derrick has remained dedicated to complete in-house manufacturing of every machine, screen panel, and tank system. Each unit is created and assembled at Derrick's Buffalo, New York headquarters facility.





### **Award-Winning Service**

Service engineers assist customers with installation, operation, and maintenance concerns, frequently solving problems over the phone. But when necessary, a team responds directly to the customer site to correct a problem. Concise, detailed, fully illustrated, easy-to-understand technical documentation is used by customers and our Service and Support team. Most questions can be answered in the pages of these comprehensive documents that are provided to customers in both printed and electronic formats. Information includes instructions for installing, operating, servicing, and maintaining Derrick equipment.

Offering around-the-clock field support, the Derrick Service department is dedicated to responding rapidly and providing efficient service and support. Close attention to customer needs is provided by thoroughly trained technical service, support experts, and Derrick's "always available" attitude.

# WEIGHTS & DIMENSIONS

EQUIPMENT		DIMENSIONS			
Model	Options	Width in (mm)	Length in (mm)	Height in (mm)	Weight lbs (kg)
<b>HI-G Dewatering Machine</b>	3-Panel 20 - 4" Cones	70-9/16 (1792)	115-9/16 (2935)	94-1/16 (2389)	5000 (2268)
	4-Panel (2) 20 - 4" Cones	140-1/2 (3569)	137-15/16 (3503)	103-3/16 (2622)	8200 (3719)
<b>HI-G Fines Recovery System</b>	3-Panel 20 - 4" Cones	205-7/8 (5229)	152-3/4 (3880)	204-1/2 (5194)	18000 (8165)
	4-Panel (2) 20 - 4" Cones	205-7/8 (5229)	220 (5588)	222-5/8 (5654)	35000 (15876)

All photographs and specifications in this publication are for general information only and are based on the latest product information available at the time of initial publication. Derrick Corporation reserves the right to change its product offering at any time without prior notice. Any reliance on any information in this publication shall be at user's own risk. For additional information, please contact the Derrick Buffalo Engineering Department.

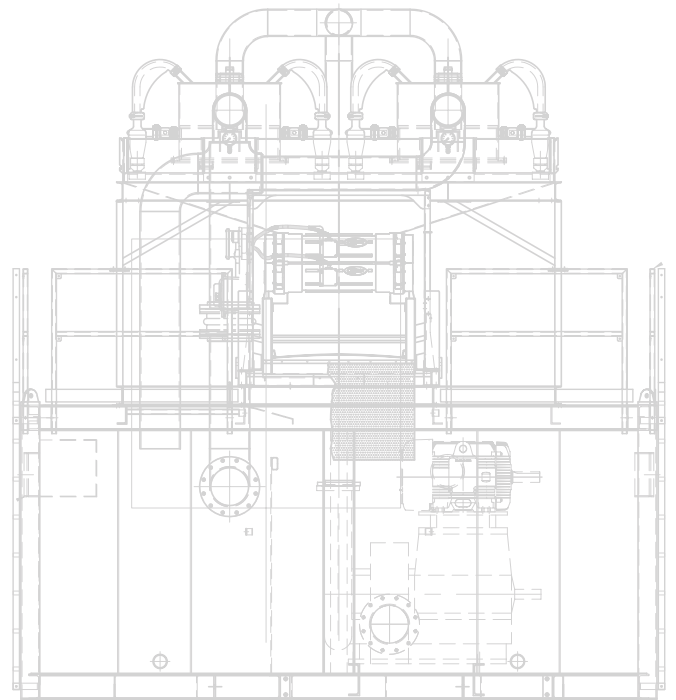
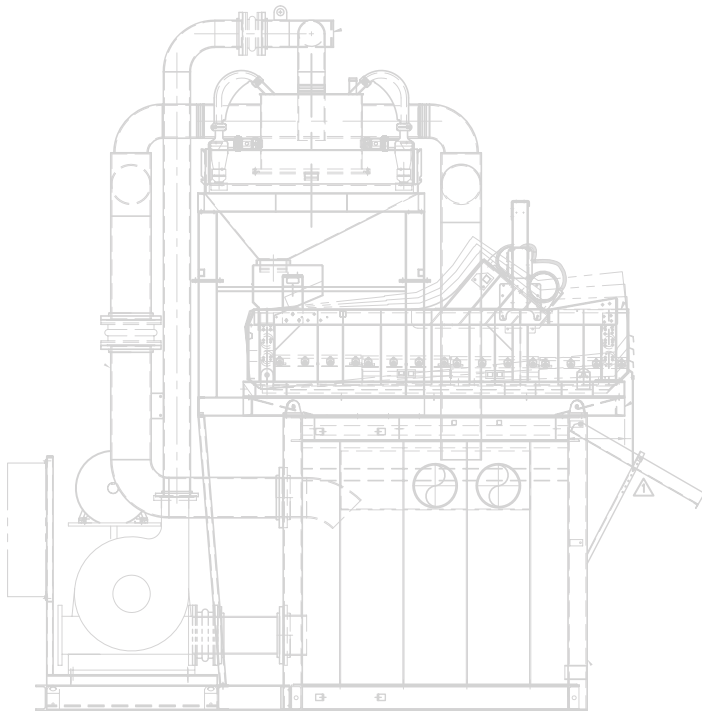



**The Derrick Family** is a community comprised of thousands of individuals in countries around the globe. We share a collective interest in **Community Enrichment** through our avid support of industry associations and charitable organizations. Aware of our worldwide impact, we support the recovery of natural resources in the most energy-efficient manner, placing vital importance on **Global Sustainability**. Our **Award-Winning Service** department works around-the-clock to provide unparalleled support to customers around the world.

Our pioneering spirit is best demonstrated by our long-term commitment to **Continuous Innovation** which drives manufacturing of our **Leading-Edge Solutions**. Clients partner with us to overcome their most difficult fine-separation challenges and we deliver with our team of **World-Class Technologists**, many of whom have been with us for well over two decades. Our vertically integrated approach ensures product dependability and reinforces our **Quality Commitment**.

We are a **Global Family**<sup>®</sup> focused on **Pioneering Technology**<sup>®</sup>.



**GLOBAL FAMILY.  
PIONEERING TECHNOLOGY.<sup>®</sup>**

590 Duke Road  
Buffalo, New York 14225 U.S.A.  
Office: (716) 683-9010  
Fax: (716) 683-4991  
Email: [info@derrick.com](mailto:info@derrick.com)  
[www.Derrick.com](http://www.Derrick.com)