



SUPER G3™ VIBRATORY MOTORS

SUPER G3™ VIBRATORY MOTORS

Proven to dramatically increase liquid/solids separation, the Derrick® Super G® series integrated vibratory motors produce superior conveyance due to their high G characteristics. Increased fluid-handling capacities using fewer shakers is only part of the reason for their success on drilling rigs. Screening finer, earlier in the drilling process, significantly reduces mud and disposal costs. The Super G series vibratory motors are built with Derrick's superior electrical components, which are renowned in the industry for durability. High performance and exceptional durability make the Super G series vibratory motors an asset to any drilling program.

The Super G3™ vibratory motor features a patented continuous, internal recirculation lubrication system that provides long life, reduced repair costs, and robust maintenance free operation. In addition to greatly extending the life of the vibratory motor, the hydrodynamic cushioning effect on bearing surfaces created by this unique lubrication system reduces friction, wear, heat, and sound (measured at 74 +/- 4 dBA). Sealed, continuous recirculation of lubricating oil maintains a fresh film of oil on all bearing surfaces at all times and prevents entry of contaminants. The Super G3 vibratory motor carries a three-year warranty.

Features & Benefits

- Zero maintenance
- Patented continuous internal oil recirculating lubrication system
- Powerful, quiet, dual vibratory motors apply high G performance
- Superior conveyance
- Low sound production (74 +/- 4 dBA)
- Low energy consumption (2.5 HP)
- Manufactured with the highest quality materials
- Three-year warranty

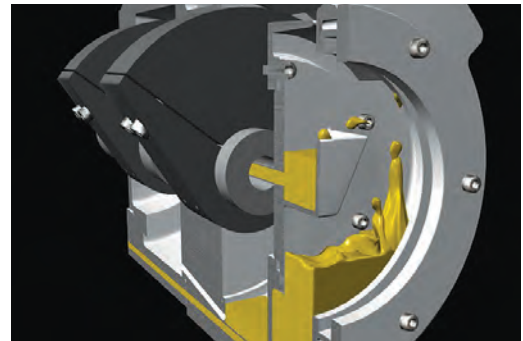

Patented continuous internal oil recirculating lubrication system

Available Certifications

- CEC/NEC (Class I, Div 1, Groups C and D)
- CEC/NEC (Class II, Div 1, Groups E, F, and G)
- ATEX (II 2G Ex db IIB T3 Gb)
- IECEX (Ex db IIB T3 Gb)
- ATEX (II 2D Ex tb IIIC T200C Db)
- IECEX (Ex tb IIIC T200C Db)
- ISO 9001: 2015



GLOBAL FAMILY.
PIONEERING TECHNOLOGY.®

Mining & Industrial Division:

590 Duke Road
Buffalo, New York 14225 U.S.A.

Office: (716) 683-9010
Fax: (716) 683-4991

Email: info@derrick.com
Web: www.Derrick.com

Drilling and Civil Construction Divisions:

15630 Export Plaza Drive
Houston, Texas 77032 U.S.A.

Office: (281) 590-3003
Toll Free: (866) DERRICK
Fax: (281) 442-6948

All photographs and specifications in this publication are for general information only and are based on the latest product information available at the time of initial publication. Derrick Corporation reserves the right to change its product offering at any time without prior notice. Any reliance on any information in this publication shall be at user's own risk. For additional information, please contact the Derrick Houston Engineering Department.